

# Icematic®

## N90S

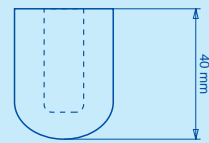

Ice cubers

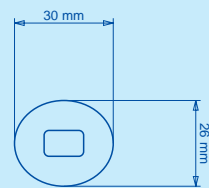

APPROVED

Ice produced for 24 hours up to

**kg. 90**

ICE PRODUCTION

Condensing unit cooling **air** or water: consumption n. 37 litres per hour\*

**WATER COOLED**

Absorbed power **W.650**

Expansion system **by capillary**

Refrigerant **R 134a**

Water inlet connection **3/4" Gas**

Water output connection **mm. Ø 20**

Single phase input/  
**220V-240V - 50 Hz**

Extra voltages: **on request**

Storage bin **kg. 27**

External structure **standard (1)**

Net weight **kg. 67**

Water temperature

Ambient temperature

| °C  | 32° | 21° | 15° | 10° |    |
|-----|-----|-----|-----|-----|----|
| 10° | 77  | 84  | 87  | 90  | kg |
| 21° | 71  | 77  | 81  | 84  | kg |
| 32° | 70  | 76  | 79  | 82  | kg |
| 38° | 66  | 71  | 74  | 76  | kg |

Ice prod. per 24 h

**AIR COOLED**

Water temperature

Ambient temperature

| °C  | 32° | 21° | 15° | 10° |    |
|-----|-----|-----|-----|-----|----|
| 10° | 75  | 83  | 87  | 90  | kg |
| 21° | 70  | 76  | 80  | 82  | kg |
| 32° | 62  | 67  | 70  | 72  | kg |
| 38° | 50  | 54  | 56  | 58  | kg |

Ice prod. per 24 h

Panels in skinplate blue coloured

(\*) with water temperature 15 °C

**Dimensions**

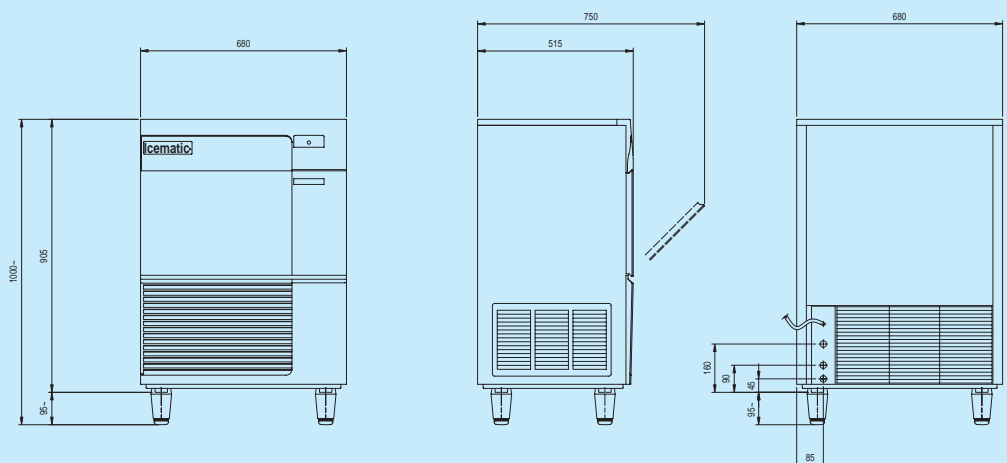

## Castel MAC SpA



**Aishwarya Consolidates Pvt. Ltd.,**  
 #19, Frist Floor, 10<sup>th</sup> 'B' Main, 27<sup>th</sup> Cross,  
 Third Block Jayanagar, BANGALORE – 560 011, INDIA  
 Tel: +91-80-2664 1200/1/2 Fax: +91-80-2664 1204  
 E-mail : [aishtek@vsnl.com](mailto:aishtek@vsnl.com) [www.aishwaryaconsolidates.com](http://www.aishwaryaconsolidates.com)